



FW & SW
TUNGALOY



TURNLINE

Tungaloy Report No. 434-E

w w w . t u n g a l o y . c o m



New wiper insert series for advanced turning operations

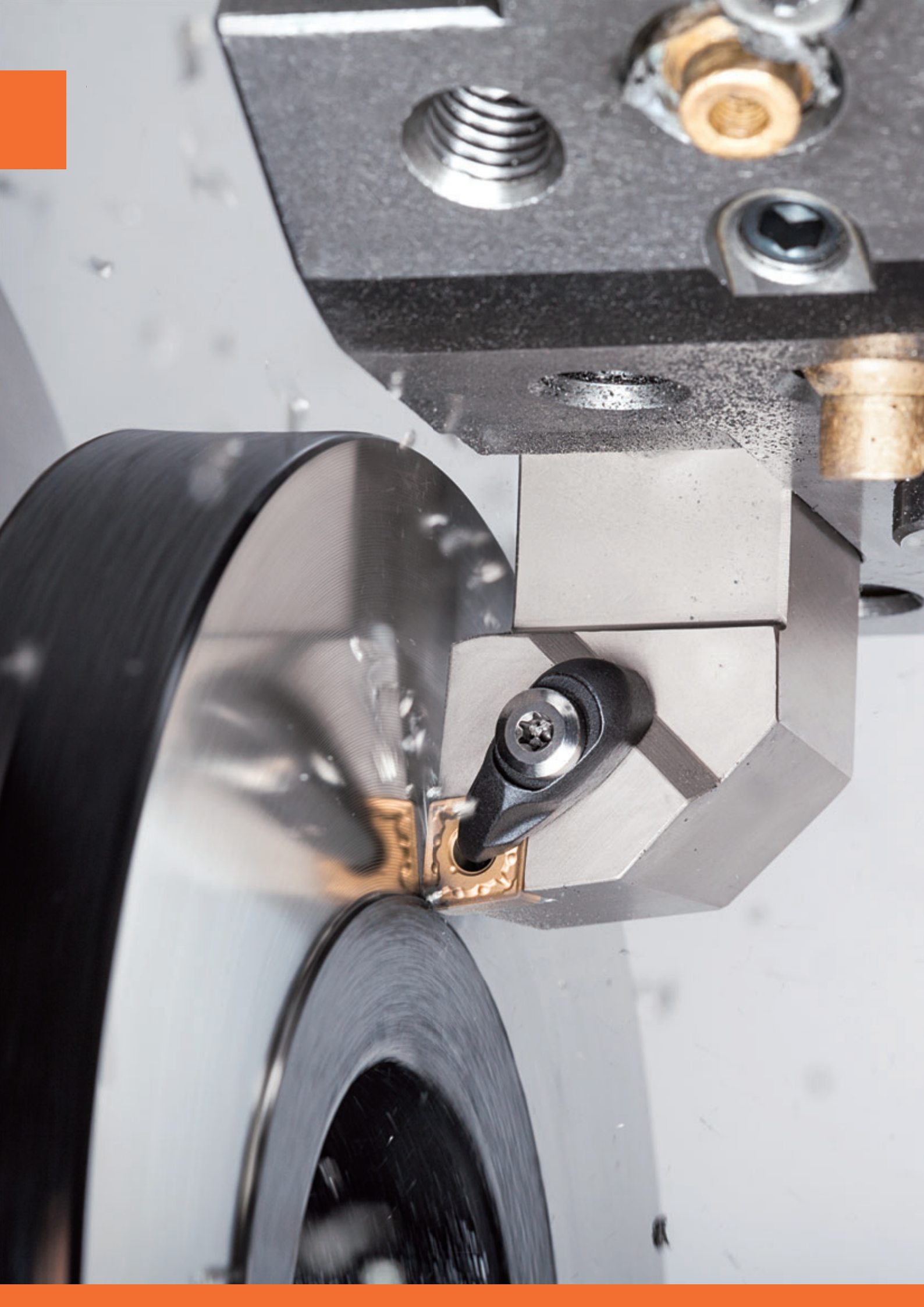

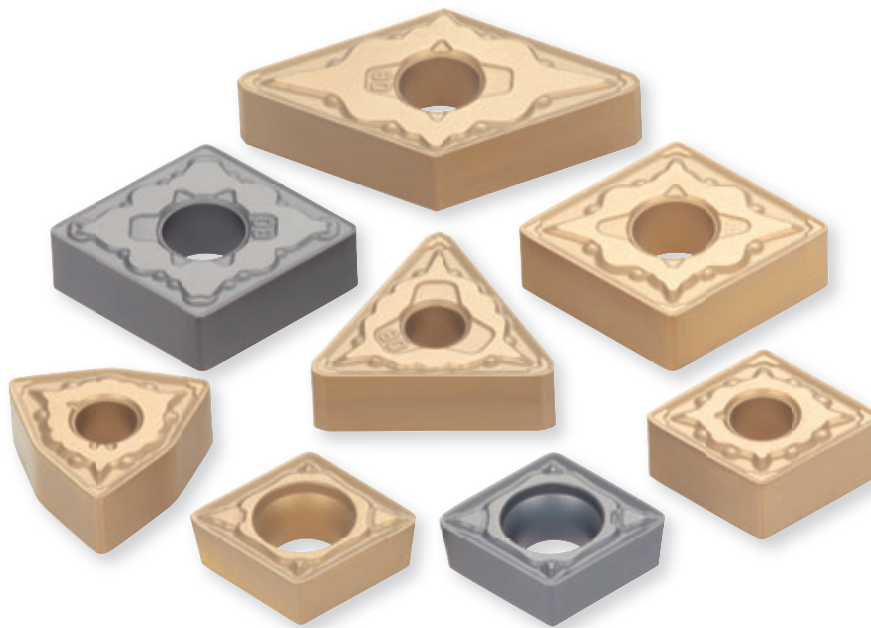

FW & SW
TUNGALOY

**Only half the surface roughness
even at doubled feed rate**
compared to regular ISO insert
without wiper

FW & SW

TUNGALOY

Highly efficient machining due to uniquely designed wiper shape

● New chipbreakers with wiper edge

New

FW Finishing

P

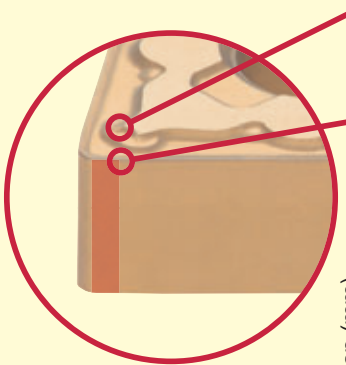

Stable chip control

Newly designed “Two-Stage Protrusion” offers stable chip control in machining with low depth of cut

Excellent surface finish

Wiper edge with radius shape provides good surface quality

Application area and chip control

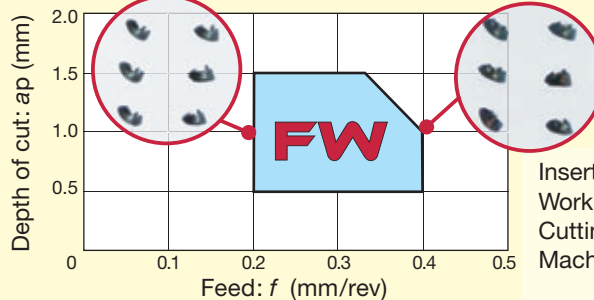

Insert : CNMG120408-FW
 Workpiece : S45C / C45
 Cutting speed : $V_c = 250$ m/min
 Machining : External turning (Continuous cutting)

New

SW Finishing to medium cutting

P K

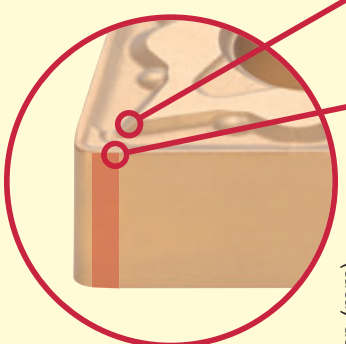

Stable chip control

Newly developed “Two-Stage bottom” design provides stable chip control in a wide range of depth of cut

Excellent surface finish

Wiper edge with radius shape provides good surface quality even at high feed

Application area and chip control

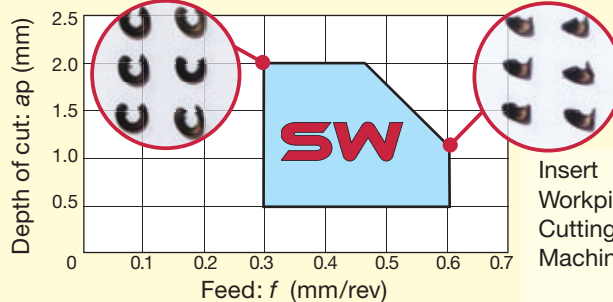

Insert : CNMG120408-SW
 Workpiece : S45C / C45
 Cutting speed : $V_c = 250$ m/min
 Machining : External turning (Continuous cutting)

● Excellent surface roughness

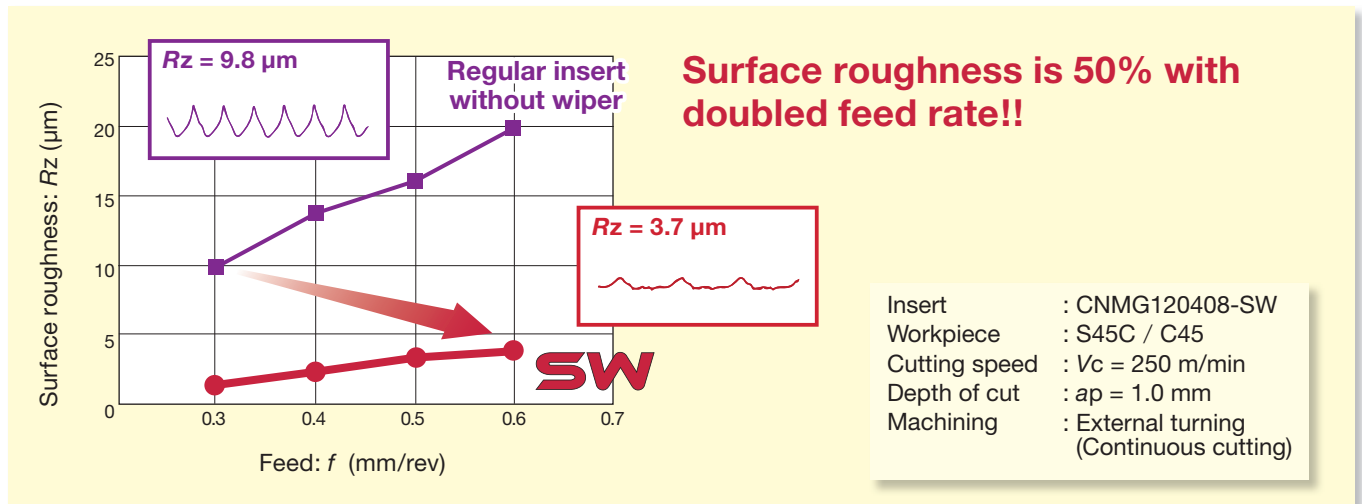

● Wiper edge on small-sized Eco inserts



Wiper inserts are available in EcoTurn series

Downsized inserts with the same thickness and chipbreaker geometry as regular-sized inserts.

ECOTURN
CNMG090408E type

Regular size
CNMG120408 type

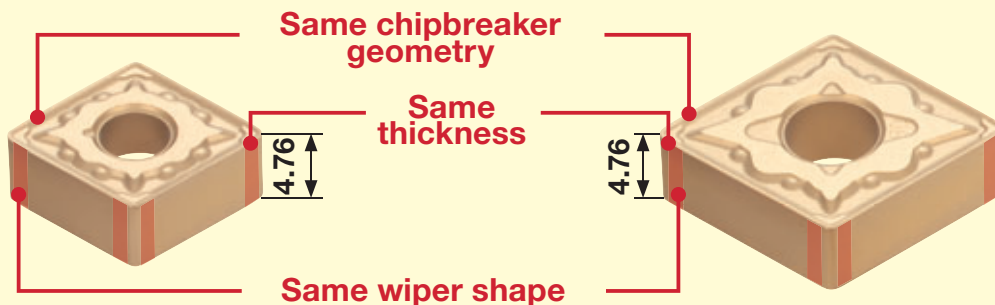

● Incredible productivity with high-pressure coolant system

Wiper insert on TungJet improves productivity and provides good surface quality in machining at high speed and feed.

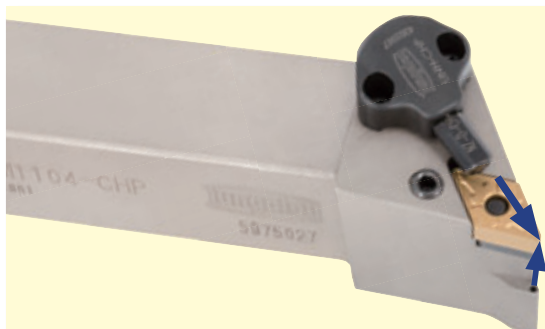

Please refer to Tungaloy Report No.432 for the details of TungJet series.

● Wiper edge on 100° corner of CNMG type insert

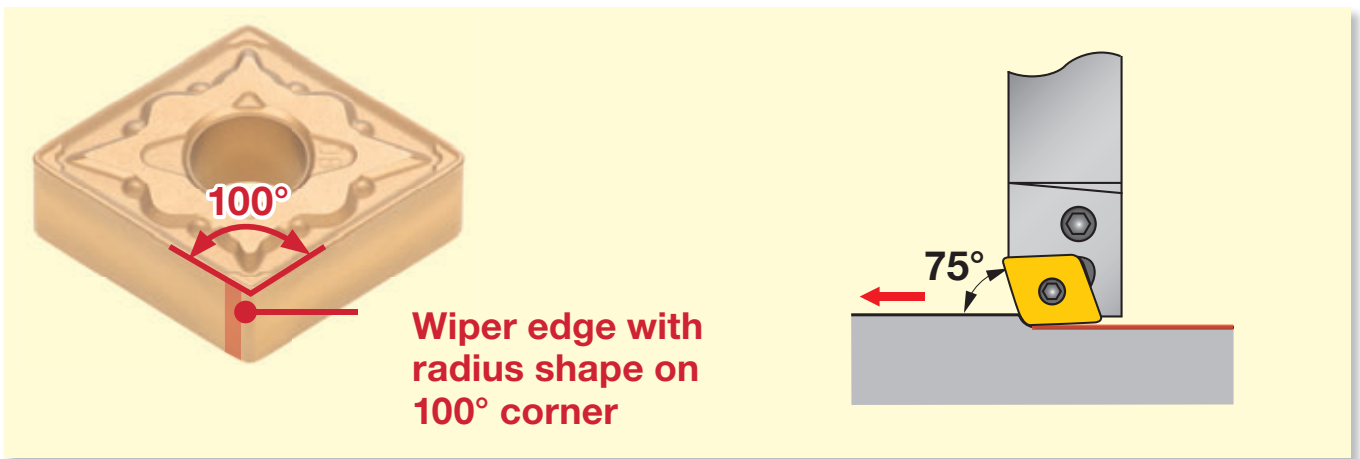

● Toolholders for wiper inserts

Wiper edges are effective when used on specific toolholders with the appropriate angle of frontal cutting edge.

Insert shape	CNMG, WNMG CCMT	DNMG	TNMG
Cutting edge style			

For high-feed machining, Turning A series toolholders with double-clamping system are recommended.

● Cautions in using wiper inserts

Radius shape and chamfering

- Wiper edge is not effective
- **The adjustment is required in NC program**

Value of adjustment for corner radius

Corner radius: r_E (mm)	0.4	0.8	1.2
Adjustment (mm)	0.28	0.60	0.96

- Machining of radius shape

- Chamfering

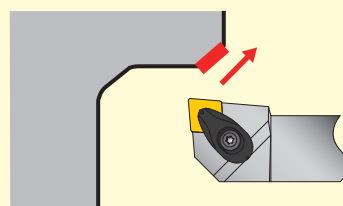
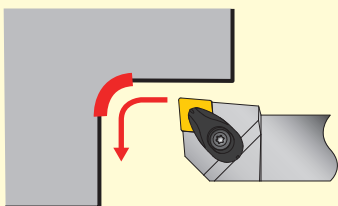

The appropriate adjustment provides the same result as standard ISO inserts.

Inserts Negative type

Rhombic / 80°

Application	Chipbreaker		Cat. No	Grades							Dimensions (mm)			
	Appearance (Cross section)	f - ap		Coated				Cermet	Coated cermet		I.C.dia	Thick- ness	Hole dia	Corner radius
				T9105	T9115	T9125	T5115		NS9530	GT9530				
Finishing	FW 		CNMG090404E-FW	●	●	●	●	●	●	9.525	4.76	3.81	0.4	
			CNMG090408E-FW	●	●	●	●	●	●	9.525	4.76	3.81	0.8	
			CNMG120404-FW	●	●	●	●	●	●	12.7	4.76	5.16	0.4	
			*CNMG120408-FW	●	●	●	●	●	●	12.7	4.76	5.16	0.8	
Finishing to medium cutting	SW 		CNMG090408E-SW	●	●	●	●	●	●	9.525	4.76	3.81	0.8	
			CNMG090412E-SW	●	●	●	●	●	●	9.525	4.76	3.81	1.2	
			*CNMG120408-SW	●	●	●	●	●	●	12.7	4.76	5.16	0.8	
			CNMG120412-SW	●	●	●	●	●	●	12.7	4.76	5.16	1.2	

Rhombic / 55°

Application	Chipbreaker		Cat. No	Grades							Dimensions (mm)				
	Appearance (Cross section)	f - ap		Coated				Cermet	Coated cermet		I.C.dia	Thick- ness	Hole dia	Corner radius	
				T9105	T9115	T9125	T5115		NS9530	GT9530					
Finishing	FW 		DNMG110404E-FW	★							9.525	4.76	3.81	0.4	
			DNMG110408E-FW	★							9.525	4.76	3.81	0.8	
			DNMG150404-FW	★								12.7	4.76	5.16	0.4
			*DNMG150408-FW	★								12.7	4.76	5.16	0.8
			DNMG150604-FW	★								12.7	6.35	5.16	0.4
			DNMG150608-FW	★								12.7	6.35	5.16	0.8
Finishing to medium cutting	SW 		DNMG110408E-SW	★							9.525	4.76	3.81	0.8	
			DNMG110412E-SW	★							9.525	4.76	3.81	1.2	
			*DNMG150408-SW	★								12.7	4.76	5.16	0.8
			DNMG150412-SW	★								12.7	4.76	5.16	1.2
			DNMG150608-SW	★								12.7	6.35	5.16	0.8
			DNMG150612-SW	★								12.7	6.35	5.16	1.2

*Note: Chipbreaker cross sections are of the inserts marked *

● : Stocked items
★ : Available in 2015

Triangular / 60°

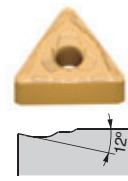
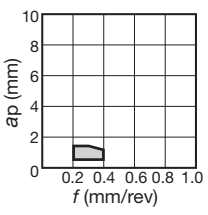
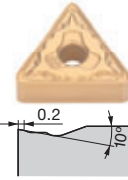
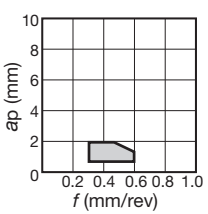
Application	Chipbreaker		f - ap	Cat. No	Grades							Dimensions (mm)					
	Appearance (Cross section)	f - ap			Coated				Cermet	Coated cermet	I.C.dia	Thick- ness	Hole dia	Corner radius			
					T9105	T9115	T9125	T5115							NS9530	GT9530	
Finishing	FW 		TNMG110404E-FW	★								6.35	4.76	2.26	0.4		
			TNMG110408E-FW	★									6.35	4.76	2.26	0.8	
			TNMG160404-FW	★										9.525	4.76	3.81	0.4
			*TNMG160408-FW	★										9.525	4.76	3.81	0.8
Finishing to medium cutting	SW 		TNMG110408E-SW	★								6.35	4.76	2.26	0.8		
			TNMG110412E-SW	★									6.35	4.76	2.26	1.2	
			*TNMG160408-SW	★										9.525	4.76	3.81	0.8
			TNMG160412-SW	★										9.525	4.76	3.81	1.2

Trigon / 80°

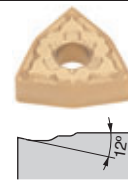
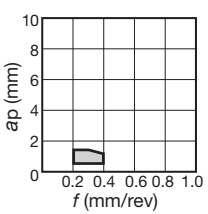
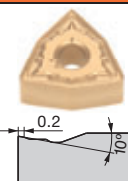
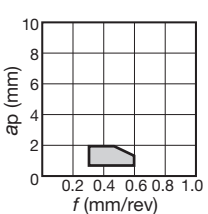
Application	Chipbreaker		f - ap	Cat. No	Grades							Dimensions (mm)					
	Appearance (Cross section)	f - ap			Coated				Cermet	Coated cermet	I.C.dia	Thick- ness	Hole dia	Corner radius			
					T9105	T9115	T9125	T5115							NS9530	GT9530	
Finishing	FW 		WNMG060404E-FW	●	●	●	●	●	●			9.525	4.76	3.81	0.4		
			WNMG060408E-FW	●	●	●	●	●	●					9.525	4.76	3.81	0.8
			WNMG080404-FW	●	●	●	●	●	●					12.7	4.76	5.16	0.4
			*WNMG080408-FW	●	●	●	●	●	●					12.7	4.76	5.16	0.8
Finishing to medium cutting	SW 		WNMG060408E-SW	●	●	●	●	●	●				9.525	4.76	3.81	0.8	
			WNMG060412E-SW	●	●	●	●	●	●					9.525	4.76	3.81	1.2
			*WNMG080408-SW	●	●	●	●	●	●					12.7	4.76	5.16	0.8
			WNMG080412-SW	●	●	●	●	●	●					12.7	4.76	5.16	1.2

*Note: Chipbreaker cross sections are of the inserts marked *

● : Stocked items
★ : Available in 2015

● Inserts Positive type

Rhombic / 80°

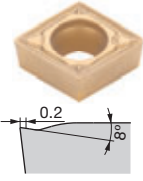
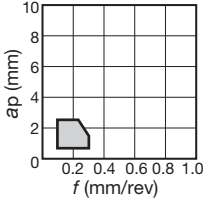
Application	Chipbreaker		Cat. No	Grades						Dimensions (mm)				
	Appearance (Cross section)	$f - a_p$		Coated				Cermet	Coated cermet		I.C.dia	Thick- ness dia	Hole radius	Corner radius
				T9105	T9115	T9125	T5115		NS9530	GT9530				
Finishing to medium cutting	SW 		CCMT060204-SW	★	★	★	★			6.35	2.38	2.80	0.4	
			CCMT060208-SW	★	★	★	★			6.35	2.38	2.80	0.8	
			CCMT09T304-SW	★	★	★	★			9.525	3.97	4.40	0.4	
			*CCMT09T308-SW	★	★	★	★			9.525	3.97	4.40	0.8	

*Note: Chipbreaker cross sections are of the inserts marked *

★ : Available in 2015

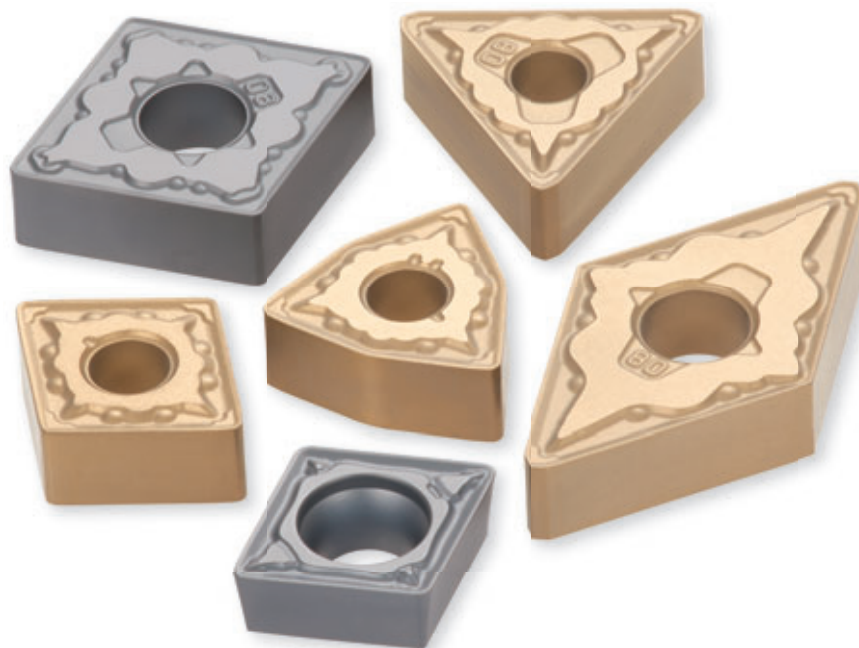

External toolholders

ACLNR/L External turning and facing A-type (Negative rake, clamp-on system)

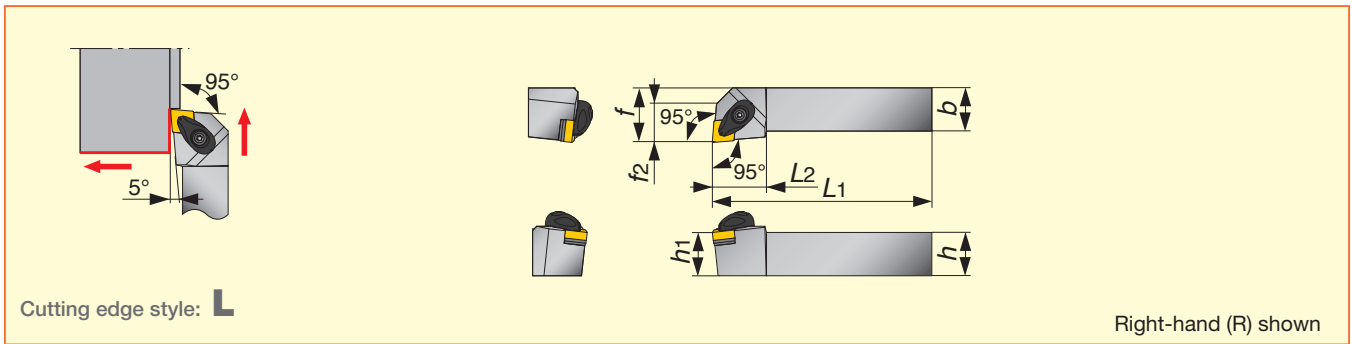

Cat. No	Stock		Dimensions (mm)							Std. corner radius r_{ϵ}	Insert	Torque (N·m)
	R	L	h	b	L_1	L_2	h_1	f	f_2			
ACLNR/L2020K0904-A	●	●	20	20	125	25	20	25	18	0.8	CN□□0904□□E	3.0
ACLNR/L2525M0904-A	●	●	25	25	150	25	25	32	18	0.8	CN□□0904□□E	3.0
ACLNR/L2020K12-A	●	●	20	20	125	26	20	25	19	0.8	CN□□1204□□	4.0
ACLNR/L2525M12-A	●	●	25	25	150	30	25	32	21	0.8	CN□□1204□□	4.0
ACLNR/L3225P12-A	●	●	32	25	170	30	32	32	21	0.8	CN□□1204□□	4.0

ADJNR/L External turning and profiling A-type (Negative rake, clamp-on system)

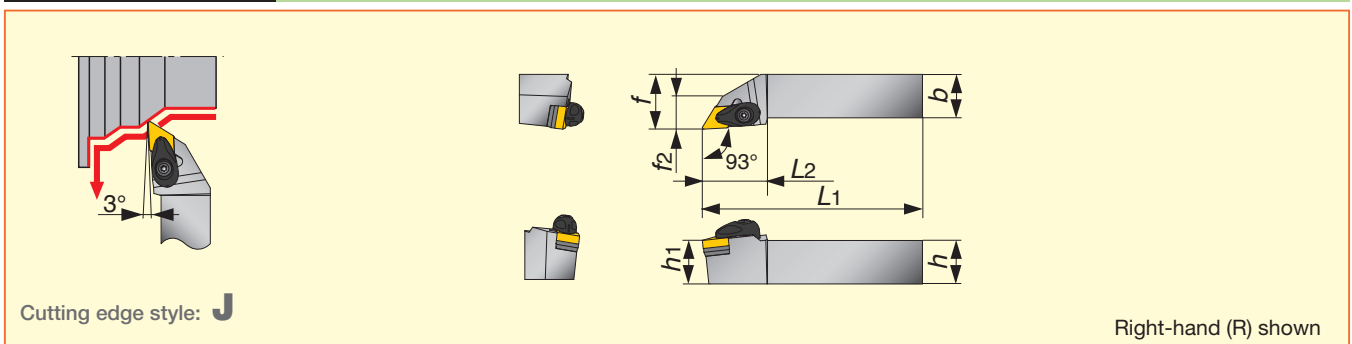

Cat. No	Stock		Dimensions (mm)							Std. corner radius r_{ϵ}	Insert	Torque (N·m)
	R	L	h	b	L_1	L_2	h_1	f	f_2			
ADJNR/L2020K1104-A	●	●	20	20	125	30	20	25	16	0.8	DN□□1104□□E	3.0
ADJNR/L2525M1104-A	●	●	25	25	150	30	25	32	19	0.8	DN□□1104□□E	3.0
ADJNR/L2020K15-A	●	●	20	20	125	36	20	25	17	0.8	DN□□1504□□	4.0
ADJNR/L2525M15-A	●	●	25	25	150	36	25	32	18	0.8	DN□□1504□□	4.0
ADJNR/L3225P15-A	●	●	32	25	170	36	32	32	18	0.8	DN□□1504□□	4.0
ADJNR/L2020K1506-A	●	●	20	20	125	36	20	25	17	0.8	DN□□1506□□	4.0
ADJNR/L2525M1506-A	●	●	25	25	150	36	25	32	18	0.8	DN□□1506□□	4.0

● : Stocked items

ATFNR/L Facing A-type (Negative rake, clamp-on system)

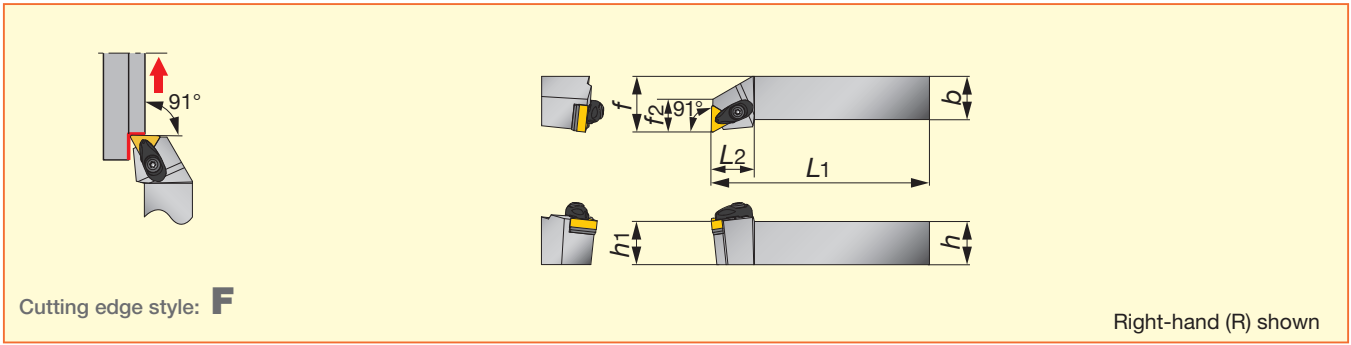

Cat. No	Stock			Dimensions (mm)					Std. corner radius r_{ϵ}	Insert	Torque (N·m)	
	R	L	h	b	L_1	L_2	h_1	f				f_2
ATFNR/L2020K16-A	●	●	20	20	125	25	20	25	18	0.8	TN□□1604□□	3.0
ATFNR/L2525M16-A	●	●	25	25	150	25	25	32	19	0.8	TN□□1604□□	3.0

ATGNR/L External turning A-type (Negative rake, clamp-on system)

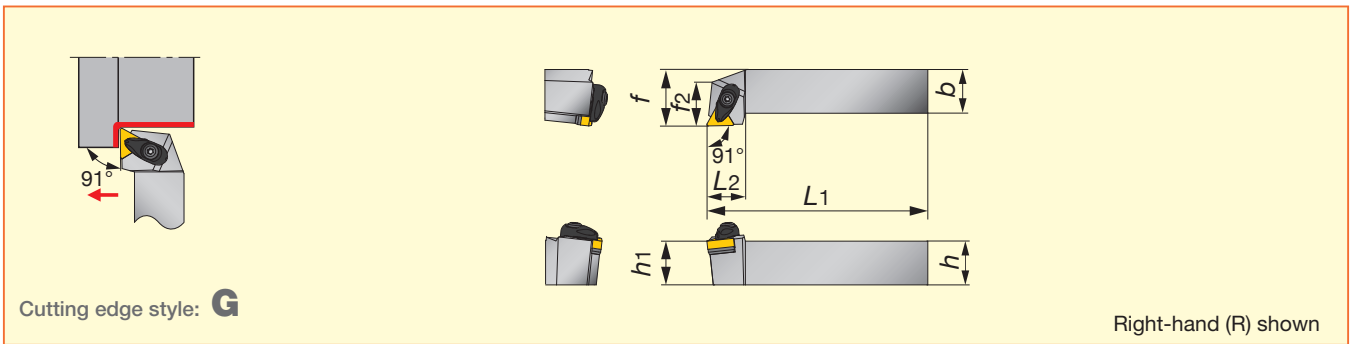

Cat. No	Stock			Dimensions (mm)					Std. corner radius r_{ϵ}	Insert	Torque (N·m)	
	R	L	h	b	L_1	L_2	h_1	f				f_2
ATGNR/L2020K16-A	●	●	20	20	125	22	20	25	22	0.8	TN□□1604□□	3.0
ATGNR/L2525M16-A	●	●	25	25	150	22	25	32	25	0.8	TN□□1604□□	3.0

ATJNR/L External turning and profiling A-type (Negative rake, clamp-on system)

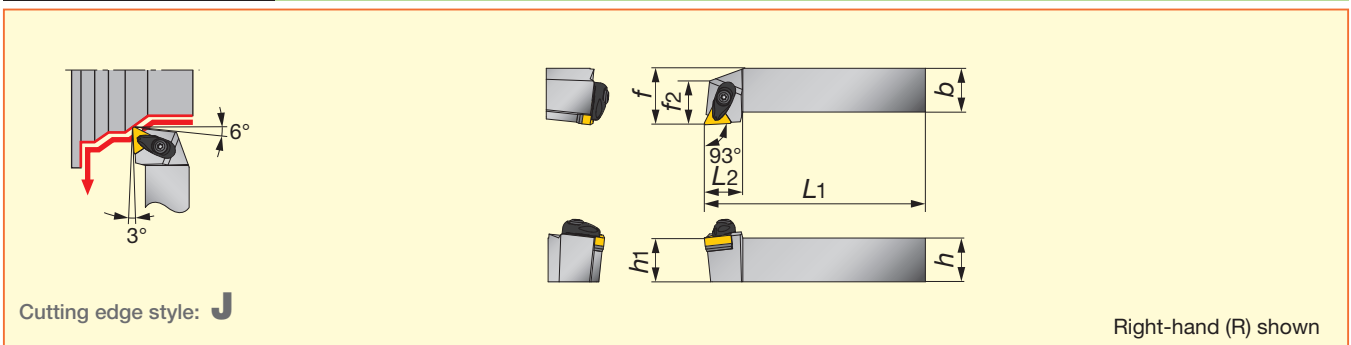

Cat. No	Stock			Dimensions (mm)					Std. corner radius r_{ϵ}	Insert	Torque (N·m)	
	R	L	h	b	L_1	L_2	h_1	f				f_2
ATJNR/L2020K16-A	●	●	20	20	125	22	20	25	23	0.8	TN□□1604□□	3.0
ATJNR/L2525M16-A	●	●	25	25	150	22	25	32	25	0.8	TN□□1604□□	3.0

● : Stocked items

AWLNR/L

External turning and facing

A-type (Negative rake, clamp-on system)

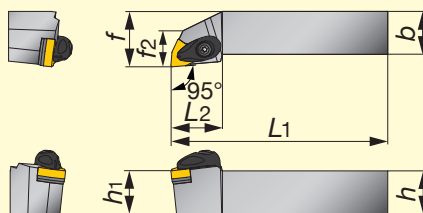
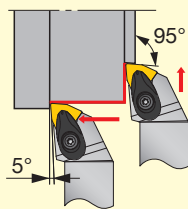

TURNING
TUNGALOY

Cutting edge style: **L**

Right-hand (R) shown

Cat. No	Stock		Dimensions (mm)							Std. corner radius r_{ϵ}	Insert	Torque (N·m)
	R	L	h	b	L_1	L_2	h_1	f	f_2			
AWLNR/L2020K0604-A	●	●	20	20	125	27	20	25	16	0.8	WN□□0604□□E	3.0
AWLNR/L2525M0604-A	●	●	25	25	150	27	25	32	23	0.8	WN□□0604□□E	3.0
AWLNR/L2020K08-A	●	●	20	20	125	30	20	25	19	0.8	WN□□0804□□	4.0
AWLNR/L2525M08-A	●	●	25	25	150	30	25	32	21	0.8	WN□□0804□□	4.0
AWLNR/L3225P08-A	●	●	32	25	170	30	32	32	21	0.8	WN□□0804□□	4.0

Parts for A-type toolholders

Toolholder Cat. No	Applicable inserts	Shim	Shim screw	Clamp	Clamping screw	Spring	Spring pin	Wrench
ACLNR/L	CN□□0904□□E	ASC322	CSTB-3.5	ACP3S-E	ACS-5W	BP-7	SP-2.5	T-15F
ACLNR/L	CN□□1204□□	ASC422	CSTB-3.5	ACP4S	ACS-5W	BP-7	SP-2.5	T-15F
ADJNR/L	DN□□1104□□E	ASD322	CSTB-3.5	ACP3S-E	ACS-5W	BP-7	SP-2.5	T-15F
ADJNR/L	DN□□1504□□	ASD432	CSTB-3.5	ACP4S	ACS-5W	BP-7	SP-2.5	T-15F
ADJNR/L	DN□□1506□□	ASD423	CSTB-3.5	ACP4S	ACS-5W	BP-7	SP-2.5	T-15F
ATGNR/L	TN□□1604□□	AST322	CSTB-3.5	ACP3S	ACS-5W	BP-7	SP-2.5	T-15F
ATFNR/L	TN□□1604□□	AST322	CSTB-3.5	ACP3S	ACS-5W	BP-7	SP-2.5	T-15F
AWLNR/L	WN□□0604□□E	ASW322	CSTB-3.5	ACP3S-E	ACS-5W	BP-7	SP-2.5	T-15F
AWLNR/L	WN□□0804□□	ASW422	CSTB-3.5	ACP4S	ACS-5W	BP-7	SP-2.5	T-15F

PCLNR/L

External turning and facing

P-type (Negative rake, lever-lock system)

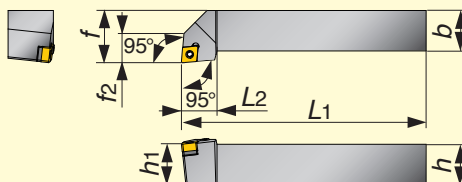
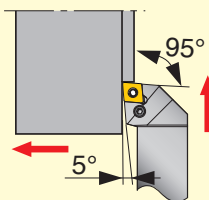

Cutting edge style: **L**

Right-hand (R) shown

Cat. No	Stock		Dimensions (mm)							Std. corner radius r_{ϵ}	Insert	Torque (N·m)
	R	L	h	b	L_1	L_2	h_1	f	f_2			
PCLNR/L2020K0904	●	●	20	20	125	20	20	25	15	0.8	CN□□0904□□E	2.0
PCLNR/L2525M0904	●	●	25	25	150	20	25	32	15	0.8	CN□□0904□□E	2.0
PCLNR/L1616	●	●	16	16	100	26	16	20	-	0.8	CN□□1204□□	3.0
PCLNR/L2020	●	●	20	20	125	28	20	25	18	0.8	CN□□1204□□	3.0
PCLNR/L2525M4	●	●	25	25	150	28	25	32	18	0.8	CN□□1204□□	3.0
PCLNR/L3225P4	●	●	32	25	170	28	32	32	18	0.8	CN□□1204□□	3.0

● : Stocked items

PCBNR/L External turning P-type (Negative rake, lever-lock system)

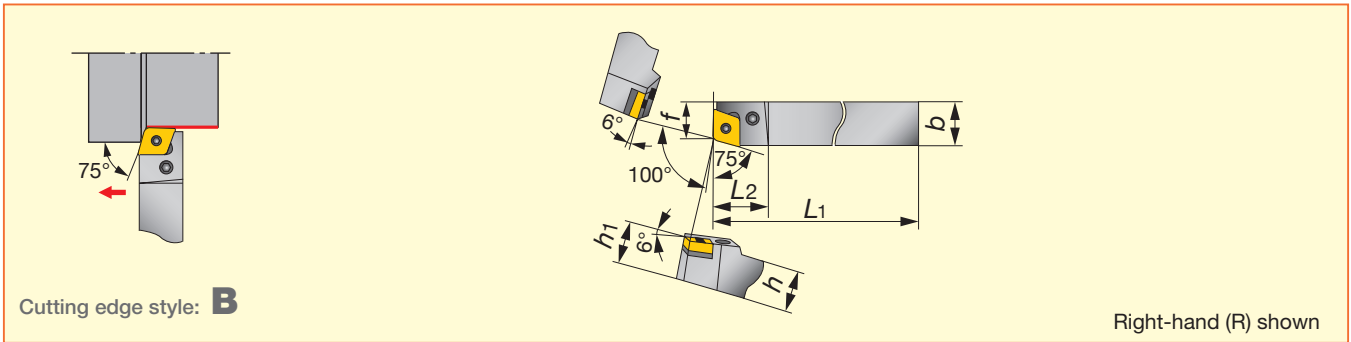

Cat. No	Stock		Dimensions (mm)							Std. corner radius r_{ϵ}	Insert	Torque (N·m)
	R	L	h	b	L_1	L_2	h_1	f	f_2			
PCBNR/L2525	●	●	25	25	150	28	25	22	-	0.8	CN□□1204□□	3.0

PDJNR/L External turning and profiling P-type (Negative rake, lever-lock system)

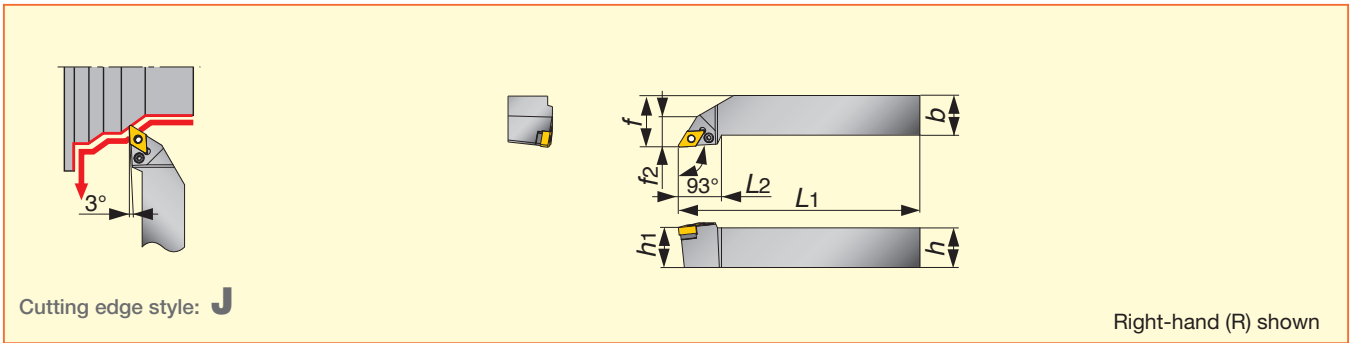

Cat. No	Stock		Dimensions (mm)							Std. corner radius r_{ϵ}	Insert	Torque (N·m)
	R	L	h	b	L_1	L_2	h_1	f	f_2			
PDJNR/L1616H1104	●	●	16	16	100	27	16	20	16	0.8	DN□□1104□□E	2.0
PDJNR/L2020K1104	●	●	20	20	125	27	20	25	16	0.8	DN□□1104□□E	2.0
PDJNR/L2525M1104	●	●	25	25	150	27	25	32	19	0.8	DN□□1104□□E	2.0
PDJNR/L2020	●	●	20	20	125	32	20	25	19	0.8	DN□□1504□□	3.0
PDJNR/L2520	●	●	25	20	150	32	25	25	19	0.8	DN□□1504□□	3.0
PDJNR/L2525	●	●	25	25	150	32	25	32	19	0.8	DN□□1504□□	3.0
PDJNR/L3225	●	●	32	25	170	32	32	32	19	0.8	DN□□1504□□	3.0

● : Stocked items

PTGNR/L External turning and profiling P-type (Negative rake, lever-lock system)

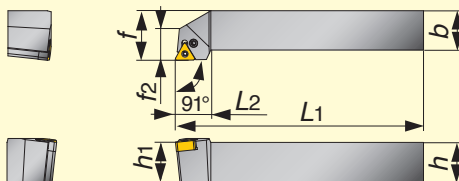
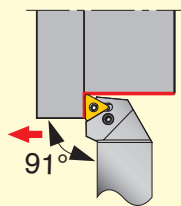

Cutting edge style: **G**

Right-hand (R) shown

Cat. No	Stock		Dimensions (mm)							Std. corner radius r_{ϵ}	Insert	Torque (N·m)
	R	L	h	b	L_1	L_2	h_1	f	f_2			
PTGNR/L2020K1104	●	●	20	20	125	20	20	25	15	0.8	TN□□1104□□E	2.0
PTGNR/L2525M1104	●	●	25	25	150	20	25	32	22.5	0.8	TN□□1104□□E	2.0
PTGNR/L1616	●	●	16	16	100	22	16	20	16	0.8	TN□□1604□□	2.0
PTGNR/L2020	●	●	20	20	125	22	20	25	16	0.8	TN□□1604□□	2.0
PTGNR/L2525M3	●	●	25	25	150	22	25	32	21	0.8	TN□□1604□□	2.0

PTFNR/L Facing P-type (Negative rake, lever-lock system)

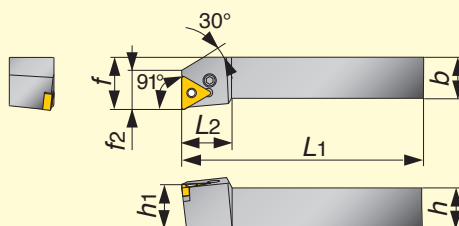
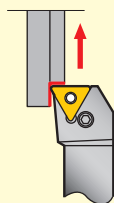

Cutting edge style: **F**

Right-hand (R) shown

Cat. No	Stock		Dimensions (mm)							Std. corner radius r_{ϵ}	Insert	Torque (N·m)
	R	L	h	b	L_1	L_2	h_1	f	f_2			
PTFNR/L2020K1104	★	★	20	20	125	16	20	25	16	0.8	TN□□1104□□E	2.0
PTFNR/L2525M1104	★	★	25	25	150	22	25	32	20	0.8	TN□□1104□□E	2.0
PTFNR/L1616	●	●	16	16	100	22	16	20	16	0.8	TN□□1604□□	2.0
PTFNR/L2020	●	●	20	20	125	22	20	25	16	0.8	TN□□1604□□	2.0
PTFNR/L2525M3	●	●	25	25	150	22	25	32	20	0.8	TN□□1604□□	2.0

PWLNRL External turning and facing P-type (Negative rake, lever-lock system)

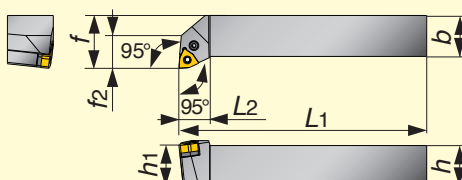
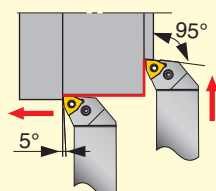

Cutting edge style: **L**

Right-hand (R) shown

Cat. No	Stock		Dimensions (mm)							Std. corner radius r_{ϵ}	Insert	Torque (N·m)
	R	L	h	b	L_1	L_2	h_1	f	f_2			
PWLNRL/L2020K0604	●	●	20	20	125	15	20	25	18	0.8	WN□□0604□□E	2.0
PWLNRL/L2525M0604	●	●	25	25	150	19	25	32	20	0.8	WN□□0604□□E	2.0

● : Stocked items
★ : Available in 2015

Parts for P-type toolholders

Toolholder Cat. No	Applicable inserts	Shim	Spring pin	Lever	Clamping screw	Wrench
PCLNR/L	CN□□0904□□E	LSC317	LSP3	LCL33	LCS3	P-2.5
PCLNR/L1616	CN□□1204□□	LSC42	LSP4	LCL4	LCS4CA	P-3.0
PCLNR/L2020	CN□□1204□□	LSC42	LSP4	LCL4	LCS4	P-3.0
PCLNR/L2525M4	CN□□1204□□	LSC42	LSP4	LCL4	LCS4	P-3.0
PCLNR/L3225P4	CN□□1204□□	LSC42	LSP4	LCL4	LCS4	P-3.0
PCBNR/L2525	CN□□1204□□	LSC42	LSP4	LCL4	LCS4	P-3.0
PDJNR/L	DN□□1104□□E	ELSD32	LSP3	LCL33L	LCS3	P-2.5
PDJNR/L	DN□□1504□□	LS42	LCP4	LCL4	LCS4	P-3.0
PTGNR/L	TN□□1104□□E	-	-	LCL23	LCS23A	P-2.5
PTGNR/L	TN□□1604□□	LST317	LSP3	LCL3	LCS3	P-2.5
PTFNR/L	TN□□1104□□E	-	-	LCL23	LCS23A	P-2.5
PTFNR/L	TN□□1604□□	LST317	LSP3	LCL3	LCS3	P-2.5
PWLR/L	WN□□0604□□E	LSW312	LSP3	LCL3	LCS3	P-2.5

SCLCR/L External turning and facing S-type (Positive rake, screw-on system)

Cutting edge style:

Right-hand (R) shown

Cat. No	Stock		Dimensions (mm)							Std. corner radius r_E	Insert	Torque (N·m)
	R	L	h	b	L_1	L_2	h_1	f	f_2			
SCLCR/L1616H09	●	●	16	16	100	16	16	20	-	0.8	CC□□09T3□□	3.5

● : Stocked items

Parts for S-type toolholders

Toolholder Cat. No	Applicable inserts	Shim	Clamping screw	Wrench	Shim screw	Wrench
SCLCR/L1616H09	CC□□09T3□□	SSC32	CSTB-3.5L	T-15F	DTS5-3.5	P-3.5

PCLNR/L External turning and facing CHP-type (Negative rake, lever-lock system)

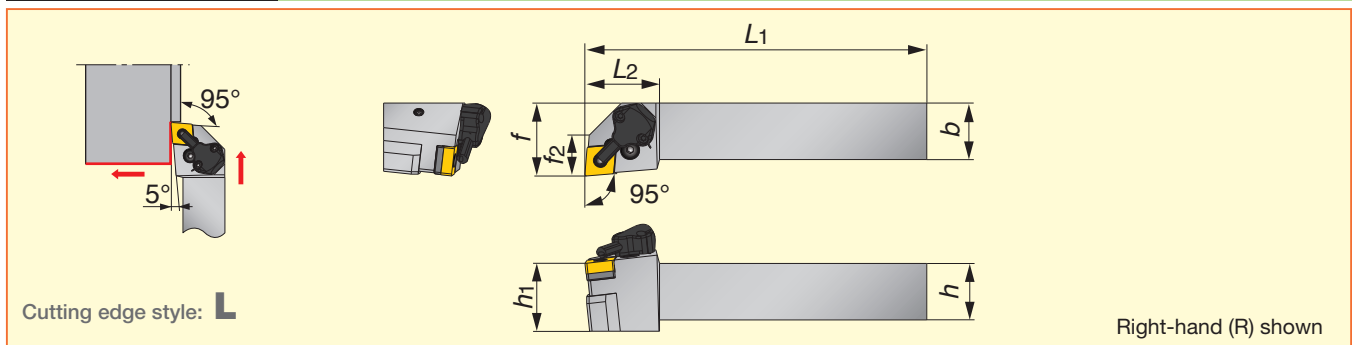

Cat. No	Stock		Dimensions (mm)						Std. corner radius r_{ϵ}	Insert	Torque (N·m)	
	R	L	h	b	L_1	L_2	h_1	f				f_2
PCLNR/L2525M0904-CHP	●	●	25	25	150	33	25	32	18	0.8	CN□□0904□□E	2.0
PCLNR/L2525M12-CHP	●	●	25	25	150	33	25	32	18	0.8	CN□□1204□□	3.0

PDJNR/L External turning and profiling CHP-type (Negative rake, lever-lock system)

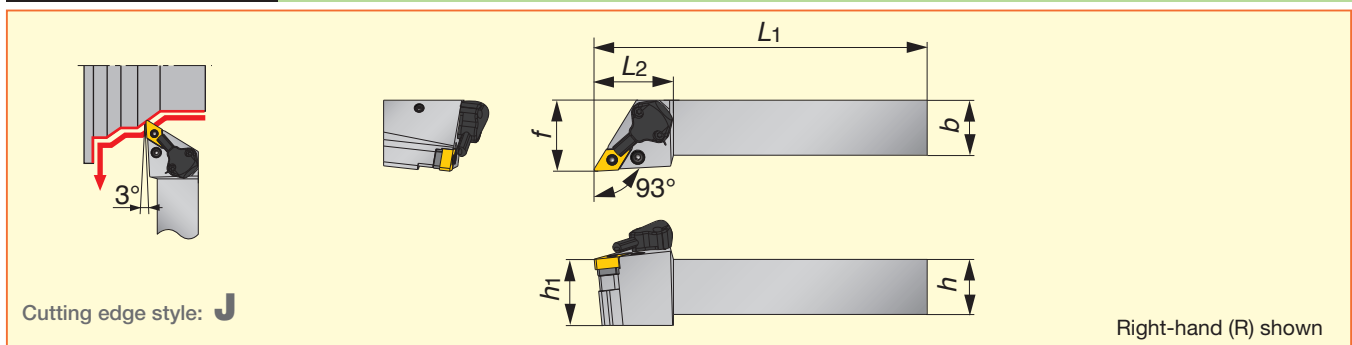

Cat. No	Stock		Dimensions (mm)						Std. corner radius r_{ϵ}	Insert	Torque (N·m)	
	R	L	h	b	L_1	L_2	h_1	f				f_2
PDJNR/L2525M1104-CHP	●	●	25	25	150	36	25	32	-	0.8	DN□□1104□□E	2.0
PDJNR/L2525M15-CHP	●	●	25	25	150	36	25	32	-	0.8	DN□□1504□□	3.0

Parts for P-CHP-type toolholders

● : Stocked items

Toolholder Cat. No	Applicable inserts	Shim	Clamping screw	Wrench for clamping screw	Spring pin	Lever	Coolant screw	Wrench for coolant screw
PCLNR/L2525M0904-CHP	CN□□0904□□E	LSC317	LCS3	P-2.5	LSP3	LCL33	SRM4X4 TL360	P-2
PCLNR/L2525M12-CHP	CN□□1204□□	LSC42	LCS4	P-3	LSP4	LCL4	SRM4X4 TL360	P-2
PDJNR/L2525M1104-CHP	DN□□1104□□E	ELSD32	LCS3	P-2.5	LSP3	LCL33L	SRM4X4 TL360	P-2
PDJNR/L2525M15-CHP	DN□□1504□□	LSD43A	LCS4	P-3	LSP4	LCL4	SRM4X4 TL360	P-2

Coolant set

Toolholder Cat. No	Applicable inserts	Coolant unit	Mounting screw	Wrench for mounting screw	O-ring
PCLNR/L2525M0904-CHP	CN□□0904□□E	CU-CW-CHP	SRM3	T-8F	OR6.4X0.9N
PCLNR/L2525M12-CHP	CN□□1204□□	CU-CW-CHP	SRM3	T-8F	OR6.4X0.9N
PDJNR/L2525M1104-CHP	DN□□1104□□E	CU-D-CHP	SRM3	T-8F	OR6.4X0.9N
PDJNR/L2525M15-CHP	DN□□1504□□	CU-D-CHP	SRM3	T-8F	OR6.4X0.9N

Internal toolholders

SCLCR/L Boring and internal facing S-type (Positive rake, screw-on system)

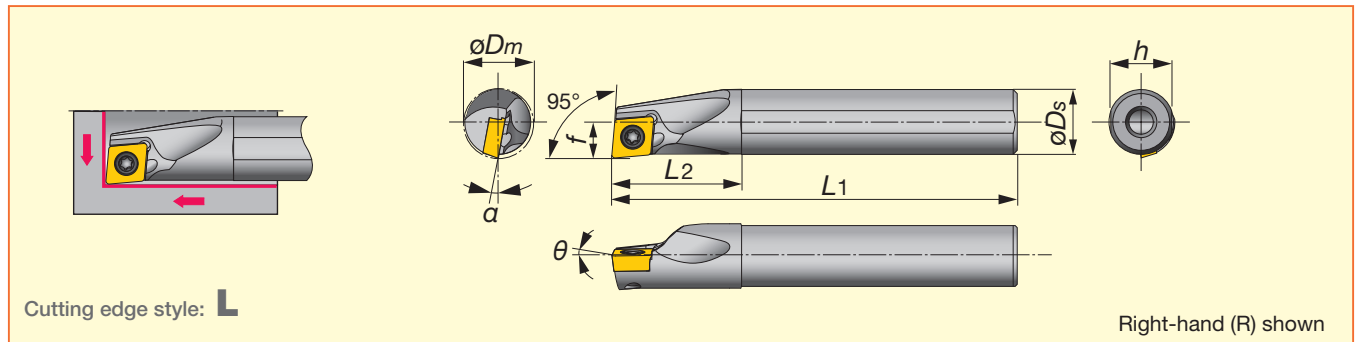

Steel shank

Cat. No	Stock		Min. bore. dia. ϕD_m	Dimensions (mm)							Std. corner radius r_ϵ	Insert	Parts		Torque	
	R	L		ϕD_s	f	L_1	L_2	h	f_2	α			θ	Clamping screw		Wrench (N·m)
A08H-SCLCR/L06-D100	●	●	10	8	5.5	100	16	7.5	-	-13°	0°	0.4	CC□□0602□□	CSTB-2.5S	T-8F	1.2
A10F-SCLCR/L06-D120	●		12	10	6	80	20	9	-	-10°	0°	0.4	CC□□0602□□	CSTB-2.5S	T-8F	1.2
A10K-SCLCR/L06-D120	●	●	12	10	6	125	20	9	-	-10°	0°	0.4	CC□□0602□□	CSTB-2.5S	T-8F	1.2
A12H-SCLCR/L06-D140	●		14	12	7	100	24	11	-	-8°	0°	0.4	CC□□0602□□	CSTB-2.5S	T-8F	1.2
A12M-SCLCR/L06-D140	●	●	14	12	7	150	24	11	-	-8°	0°	0.4	CC□□0602□□	CSTB-2.5S	T-8F	1.2
A12H-SCLCR/L06-D160	●		16	12	9	100	24	11	-	-7°	0°	0.4	CC□□0602□□	CSTB-2.5S	T-8F	1.2
A12M-SCLCR/L06-D160	●	●	16	12	9	150	24	11	-	-7°	0°	0.4	CC□□0602□□	CSTB-2.5S	T-8F	1.2
A16K-SCLCR/L09-D180	●		18	16	9	125	32	15	-	-9°	0°	0.8	CC□□09T3□□	CSTB-4S	T-15F	3.0
A16Q-SCLCR/L09-D180	●	●	18	16	9	180	32	15	-	-10°	0°	0.8	CC□□09T3□□	CSTB-4S	T-15F	3.0
A16K-SCLCR/L09-D200	●		20	16	11	125	32	15	-	-9°	0°	0.8	CC□□09T3□□	CSTB-4S	T-15F	3.0
A16Q-SCLCR/L09-D200	●	●	20	16	11	180	32	15	-	-9°	0°	0.8	CC□□09T3□□	CSTB-4S	T-15F	3.0
A20R-SCLCR/L09-D220	●	●	22	20	11	200	32	18	-	-8°	0°	0.8	CC□□09T3□□	CSTB-4S	T-15F	3.0
A25S-SCLCR/L09-D270	●	●	27	25	13.5	250	45	23	-	-6°	0°	0.8	CC□□09T3□□	CSTB-4S	T-15F	3.0

Carbide shank

Cat. No	Stock		Min. bore. dia. ϕD_m	Dimensions (mm)							Std. corner radius r_ϵ	Insert	Parts		Torque	
	R	L		ϕD_s	f	L_1	L_2	h	f_2	α			θ	Clamping screw		Wrench (N·m)
E08G-SCLCR/L06-D100	●		10	8	5.5	90	22	7.5	-	-13°	0°	0.4	CC□□0602□□	CSTB-2.5S	T-8F	1.2
E08K-SCLCR/L06-D100	●	●	10	8	5.5	125	22	7.5	-	-13°	0°	0.4	CC□□0602□□	CSTB-2.5S	T-8F	1.2
E10F-SCLCR/L06-D120	●		12	10	6	80	25	9	-	-10°	0°	0.4	CC□□0602□□	CSTB-2.5S	T-8F	1.2
E10H-SCLCR/L06-D120	●		12	10	6	100	25	9	-	-10°	0°	0.4	CC□□0602□□	CSTB-2.5S	T-8F	1.2
E10M-SCLCR/L06-D120	●	●	12	10	6	150	25	9	-	-10°	0°	0.4	CC□□0602□□	CSTB-2.5S	T-8F	1.2
E12G-SCLCR/L06-D140	●		14	12	7	90	27	11	-	-8°	0°	0.4	CC□□0602□□	CSTB-2.5S	T-8F	1.2
E12J-SCLCR/L06-D140	●		14	12	7	110	27	11	-	-8°	0°	0.4	CC□□0602□□	CSTB-2.5S	T-8F	1.2
E12Q-SCLCR/L06-D140	●	●	14	12	7	180	27	11	-	-8°	0°	0.4	CC□□0602□□	CSTB-2.5S	T-8F	1.2
E12G-SCLCR/L06-D160	●		16	12	9	90	27	11	-	-7°	0°	0.4	CC□□0602□□	CSTB-2.5S	T-8F	1.2
E12J-SCLCR/L06-D160	●		16	12	9	110	27	11	-	-7°	0°	0.4	CC□□0602□□	CSTB-2.5S	T-8F	1.2
E12Q-SCLCR/L06-D160	●	●	16	12	9	180	27	11	-	-7°	0°	0.4	CC□□0602□□	CSTB-2.5S	T-8F	1.2
E16H-SCLCR/L09-D180	●		18	16	9	100	32	15	-	-10°	0°	0.8	CC□□09T3□□	CSTB-4L060	T-15F	3.0
E16L-SCLCR/L09-D180	●		18	16	9	130	32	15	-	-10°	0°	0.8	CC□□09T3□□	CSTB-4L060	T-15F	3.0
E16R-SCLCR/L09-D180	●	●	18	16	9	200	32	15	-	-10°	0°	0.8	CC□□09T3□□	CSTB-4L060	T-15F	3.0
E16H-SCLCR/L09-D200	●		20	16	11	100	32	15	-	-9°	0°	0.8	CC□□09T3□□	CSTB-4L060	T-15F	3.0
E16L-SCLCR/L09-D200	●		20	16	11	130	32	15	-	-9°	0°	0.8	CC□□09T3□□	CSTB-4L060	T-15F	3.0
E16R-SCLCR/L09-D200	●	●	20	16	11	200	32	15	-	-9°	0°	0.8	CC□□09T3□□	CSTB-4L060	T-15F	3.0
E20S-SCLCR/L09-D220	●		22	20	11	250	36	18	-	-8°	0°	0.8	CC□□09T3□□	CSTB-4S	T-15F	3.0
E25T-SCLCR/L09-D270	●		27	25	13.5	300	45	23	-	-6°	0°	0.8	CC□□09T3□□	CSTB-4S	T-15F	3.0

● : Stocked items

PCLNR/L Boring and facing P-type (Negative, lever-lock system)

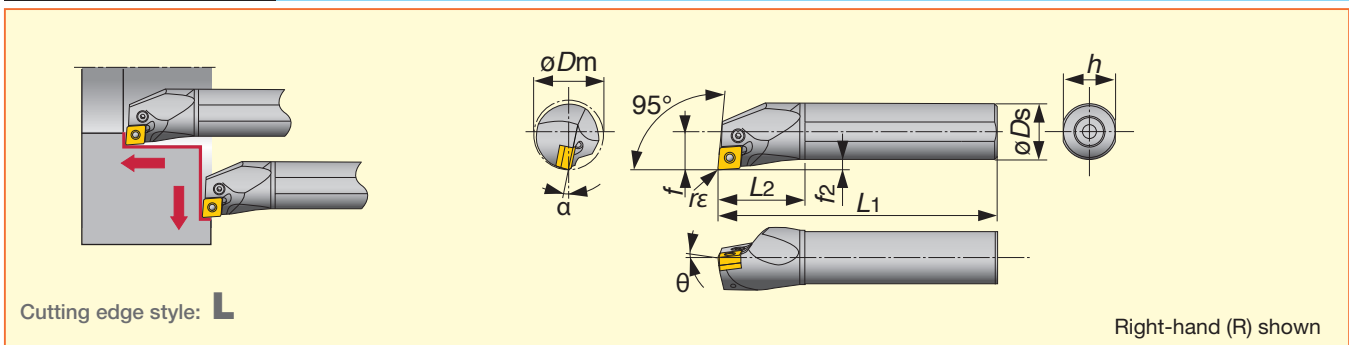

Cat. No	Stock		Min. bore. dia.		Dimensions (mm)							Std. corner radius r_E	Insert	Torque (N·m)
	R	L	ϕD_m	ϕD_s	f	L_1	L_2	h	f_2	α	θ			
A16M-PCLNR/L0904-D200	★	★	20	16	11	150	32	15	3.0	-18°	-6°	0.8	CN□□0904□□E	1.7
A20Q-PCLNR/L0904-D250	★	★	25	20	13	180	36	18	3	-12°	-6°	0.8	CN□□0904□□E	1.7
A25R-PCLNR/L12-D320	●	●	32	25	17	200	45	23	4.5	-13°	-6°	0.8	CN□□1204□□	2.7
A32S-PCLNR/L12-D400	●	●	40	32	22	250	50	30	6	-11°	-6°	0.8	CN□□1204□□	4.8
A40T-PCLNR/L12-D500	●	●	50	40	27	300	60	37	7	-10°	-6°	0.8	CN□□1204□□	4.8
A50U-PCLNR/L12-D630	●	●	63	50	35	350	65	47	10	-8°	-6°	0.8	CN□□1204□□	4.8

PDUNR/L Internal profiling P-type (Negative, lever-lock system)

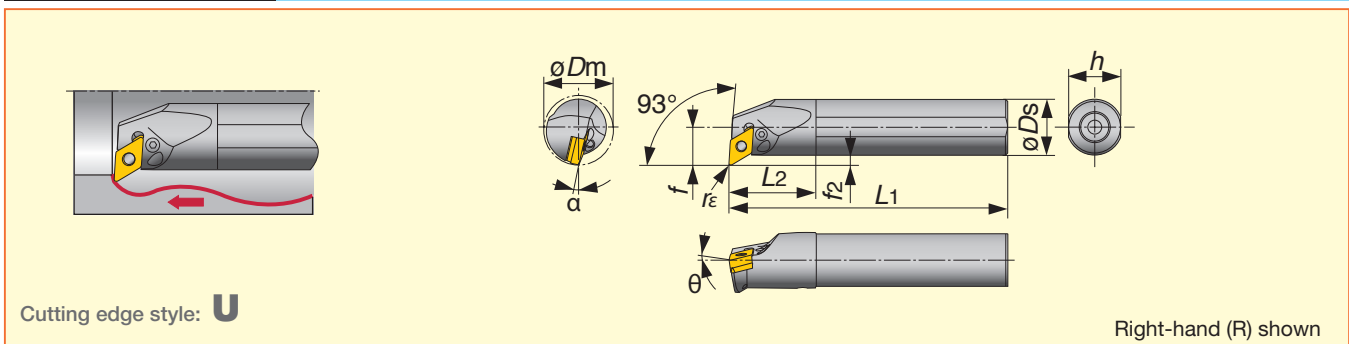

Cat. No	Stock		Min. bore. dia.		Dimensions (mm)							Std. corner radius r_E	Insert	Torque (N·m)
	R	L	ϕD_m	ϕD_s	f	L_1	L_2	h	f_2	α	θ			
A20Q-PDUNR/L1104-D250	★	★	25	20	13	180	36	18	3	-14°	-6°	0.8	DN□□1104□□E	1.7
A32S-PDUNR/L15-D400	●	●	40	32	22	250	50	30	6	-13°	-6°	0.8	DN□□1504□□	4.8
A40T-PDUNR/L15-D500	●	●	50	40	27	300	60	37	7	-10°	-6°	0.8	DN□□1504□□	4.8
A50U-PDUNR/L15-D630	●	●	63	50	35	350	65	47	10	-8°	-6°	0.8	DN□□1504□□	4.8
A32S-PDUNR/L1506-D400	●	●	40	32	22	250	50	30	6	-13°	-6°	0.8	DN□□1506□□	4.8
A40T-PDUNR/L1506-D500	●	●	50	40	27	300	60	37	7	-11°	-6°	0.8	DN□□1506□□	4.8
A50U-PDUNR/L1506-D630	●	●	63	50	35	350	65	47	10	-10°	-6°	0.8	DN□□1506□□	4.8

● : Stocked items
★ : Available in 2015

PTFNR/L Boring P-type (Negative, lever-lock system)

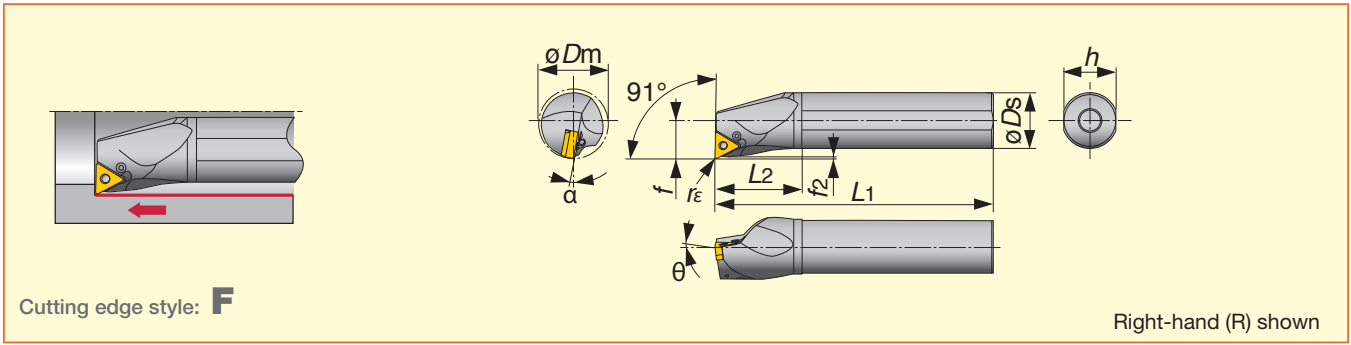





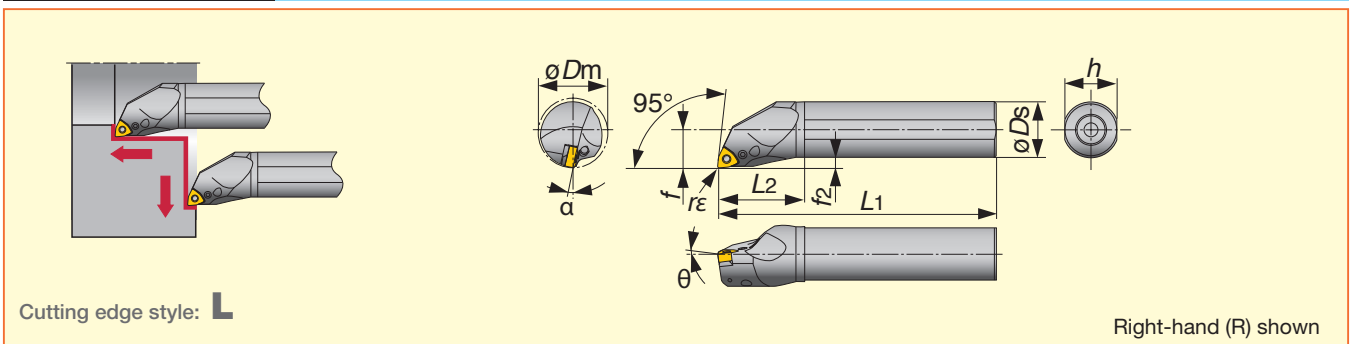

Cat. No	Stock		Min. bore. dia.		Dimensions (mm)							Std. corner radius r_ϵ	Insert	Torque (N·m)
	R	L	ϕD_m	ϕD_s	f	L_1	L_2	h	f_2	α	θ			
A25R-PTFNR/L1104-D320	★	★	32	25	17	200	45	23	1.3	-12°	-6°	0.8	TN□□1104□□E	2.0
A32S-PTFNR/L1104-D400	★	★	40	32	22	250	50	30	1.2	-10°	-6°	0.8	TN□□1104□□E	2.0
A25R-PTFNR/L16-D320	●	●	32	25	17	200	45	23	1.2	-12°	-6°	0.8	TN□□1604□□	2.7
A32S-PTFNR/L16-D400	●	●	40	32	22	250	50	30	1.1	-10°	-6°	0.8	TN□□1604□□	2.7
A40T-PTFNR/L16-D500	●	●	50	40	27	300	60	37	1.1	-10°	-6°	0.8	TN□□1604□□	2.7
A50U-PTFNR/L16-D630	●	●	63	50	35	350	65	47	1.1	-8°	-6°	0.8	TN□□1604□□	2.7

PWLNR/L Boring and facing P-type (Negative, lever-lock system)



Cat. No	Stock		Min. bore. dia.		Dimensions (mm)							Std. corner radius r_ϵ	Insert	Torque (N·m)
	R	L	ϕD_m	ϕD_s	f	L_1	L_2	h	f_2	α	θ			
A16M-PWLNR/L0604-D200	★	★	20	16	11	150	32	15	3.0	-17°	-8°	0.8	WN□□0604□□E	1.7
A20Q-PWLNR/L0604-D250	★	★	25	20	13	180	36	18	3	-14°	-6°	0.8	WN□□0604□□E	1.7
A25R-PWLNR/L08-D320	●	●	32	25	17	200	45	23	4.5	-13°	-6°	0.8	WN□□0804□□	2.7
A32S-PWLNR/L08-D400	●	●	40	32	22	250	50	30	6	-11°	-6°	0.8	WN□□0804□□	4.8
A40T-PWLNR/L08-D500	●	●	50	40	27	300	60	37	7	-10°	-6°	0.8	WN□□0804□□	4.8

Parts for P-type toolholders

Toolholder Cat. No	Applicable inserts	Shim	Spring pin	Clamping screw	Lever	Coolant supply attachment	Screw for oil hole	Wrench
								
A16M-PCLNR/L0904-D200	CN□□0904□□E	-	-	LCS33	LCL33N	-	SSHM3-4	P-2F
A20Q-PCLNR/L0904-D250	CN□□0904□□E	-	-	LCS33	LCL33N	EA-20	SSHM3-4	P-2F
A25R-PCLNR/L12-D320	CN□□1204□□	-	-	LCS43	LCL43N	EA-25	SSHM5-6	P-2.5
A32S-PCLNR/L12-D400	CN□□1204□□	LCS42BR/L	LSP4	LCS4	LCL4	EA-32	SSHM5-6	P-3
A40T-PCLNR/L12-D500	CN□□1204□□	LCS42BR/L	LCS4	LCS4	LCL4	-	SSHM6-6	P-3
A50U-PCLNR/L12-D630	CN□□1204□□	LCS42BR/L	LCS4	LCS4	LCL4	-	SSHM6-6	P-3
A20Q-PDUNR/L1104-D250	DN□□1104□□E	-	-	LCS22A	LCL33NL	EA-20	SSHM2.5-3	P-2F
A32S-PDUNR/L15-D400	DN□□1504□□	LSD42BR/L	LSP4	LCS4	LCL4	EA-32	SSHM5-6	P-3
A40T-PDUNR/L15-D500	DN□□1504□□	LSD42BR/L	LSP4	LCS4	LCL4	-	SSHM6-6	P-3
A50U-PDUNR/L15-D630	DN□□1504□□	LSD42BR/L	LSP4	LCS4	LCL4	-	SSHM6-6	P-3
A32S-PDUNR/L1506-D400	DN□□1506□□	ELSD42	LSP4S	ELCS4	LCL44	EA-32	SSHM5-6	P-3
A40T-PDUNR/L1506-D500	DN□□1506□□	ELSD42	LSP4S	ELCS4	LCL44	-	SSHM6-6	P-3
A50U-PDUNR/L1506-D630	DN□□1506□□	ELSD42	LSP4S	ELCS4	LCL44	-	SSHM6-6	P-3
A25R-PTFNR/L1104-D320	TN□□1104□□E	-	-	LCS23A	LCL23	EA-25	SSHM4-5	P-2.5
A32S-PTFNR/L1104-D400	TN□□1104□□E	-	-	LCS23A	LCL23	EA-32	SSHM4-5	P-2.5
A25R-PTFNR/L16-D320	TN□□1604□□	ELST317NR/L	LSP3	LCS3	LCL33	EA-25	SSHM4-5	P-2.5
A32S-PTFNR/L16-D400	TN□□1604□□	LST317BR/L	LSP3	LCS3	LCL3	EA-32	SSHM4-5	P-2.5
A40T-PTFNR/L16-D500	TN□□1604□□	LST317BR/L	LSP3	LCS3	LCL3	-	SSHM6-6	P-2.5
A50U-PTFNR/L16-D630	TN□□1604□□	LST317BR/L	LSP3	LCS3	LCL3	-	SSHM6-6	P-2.5
A16M-PWLNR/L0604-D200	WN□□0604□□E	-	-	LCS33	LCL33N	-	SSHM3-4	P-2F
A20Q-PWLNR/L0604-D250	WN□□0604□□E	-	-	LCS33	LCL33N	EA-20	SSHM3-4	P-2F
A25R-PWLNR/L08-D320	WN□□0804□□	-	-	LCS43	LCL43N	EA-25	SSHM5-6	P-2.5
A32S-PWLNR/L08-D400	WN□□0804□□	LSW42BR/L	LSP4	LCS4	LCL4	EA-32	SSHM5-6	P-3
A40T-PWLNR/L08-D500	WN□□0804□□	LSW42BR/L	LSP4	LCS4	LCL4	-	SSHM6-6	P-3

ACLNR/L Boring and facing A-type (Negative rake, clamp-on system)

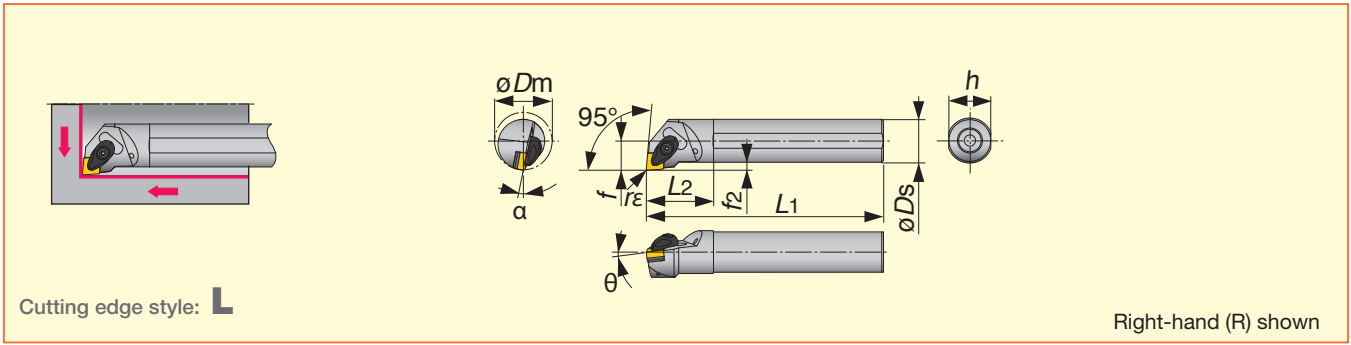

Cat. No	Stock		Min. bore. dia. ϕD_m	ϕD_s	Dimensions (mm)							Std. corner radius r_E	Insert	Torque (N·m)
	R	L			f	L ₁	L ₂	h	f ₂	α	θ			
A25R-ACLNR/L0904-D320	★	★	32	25	17	200	45	23	4.5	-13°	-6°	0.8	CN□□0904□□E	3.0
A32S-ACLNR/L0904-D400	★	★	40	32	22	250	50	30	6	-10°	-6°	0.8	CN□□0904□□E	3.0
A25R-ACLNR/L12-D320	●	●	32	25	17	200	45	23	4.5	-13°	-6°	0.8	CN□□1204□□	3.5
A32S-ACLNR/L12-D400	●	●	40	32	22	250	50	30	6	-10°	-6°	0.8	CN□□1204□□	3.5
A40T-ACLNR/L12-D500	●	●	50	40	27	300	55	37	7	-8°	-6°	0.8	CN□□1204□□	3.5
A50U-ACLNR/L12-D630	●	●	63	50	35	350	65	47	10	-7°	-6°	0.8	CN□□1204□□	3.5

ADUNR/L Boring and profiling A-type (Negative rake, clamp-on system)

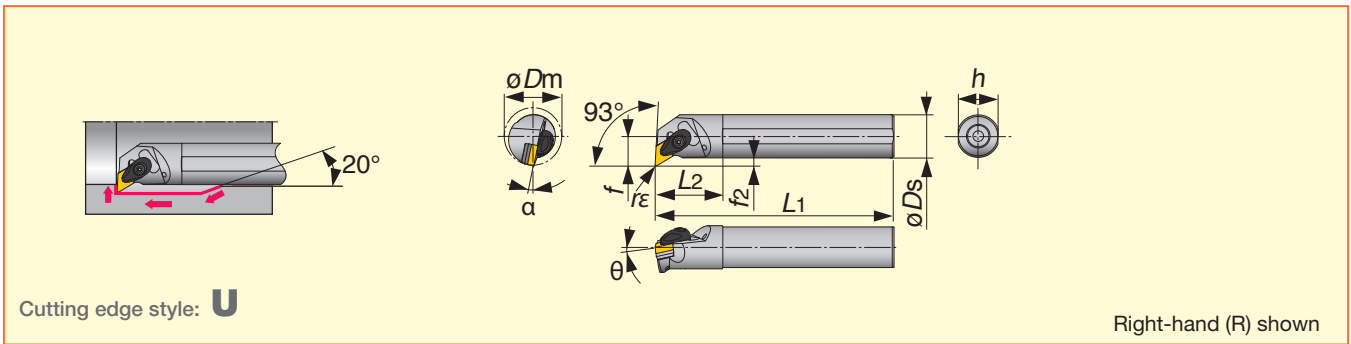

Cat. No	Stock		Min. bore. dia. ϕD_m	ϕD_s	Dimensions (mm)							Std. corner radius r_E	Insert	Torque (N·m)
	R	L			f	L ₁	L ₂	h	f ₂	α	θ			
A25R-ADUNR/L1104-D320	★	★	32	25	17	200	45	23	4.5	-13°	-6°	0.8	DN□□1104□□E	3.0
A32S-ADUNR/L1104-D400	★	★	40	32	22	250	50	30	6	-11°	-6°	0.8	DN□□1104□□E	3.0
A25R-ADUNR/L15-D320	●	●	32	25	17	200	45	23	4.5	-13°	-6°	0.8	DN□□1504□□	3.5
A32S-ADUNR/L15-D400	●	●	40	32	22	250	50	30	6	-10°	-6°	0.8	DN□□1504□□	3.5
A40T-ADUNR/L15-D500	●	●	50	40	27	300	55	37	7	-8°	-6°	0.8	DN□□1504□□	3.5
A50U-ADUNR/L15-D630	●	●	63	50	35	350	65	47	10	-7°	-6°	0.8	DN□□1504□□	3.5
A25R-ADUNR/L1506-D320	●	●	32	25	17	200	45	23	4.5	-13°	-6°	0.8	DN□□1506□□	3.5
A32S-ADUNR/L1506-D400	●	●	40	32	22	250	50	30	6	-10°	-6°	0.8	DN□□1506□□	3.5

● : Stocked items
★ : Available in 2015

ATFNR/L Blind hole boring A-type (Negative rake, clamp-on system)

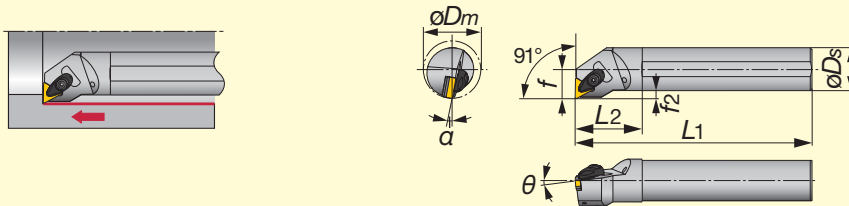

Cutting edge style: **F**

Right-hand (R) shown

Cat. No	Stock		Min. bore. dia.		Dimensions (mm)							Std. corner radius r_E	Insert	Torque (N·m)
	R	L	ϕD_m	ϕD_s	f	L_1	L_2	h	f_2	a	θ			
A25R-ATFNR/L16-D320	●	●	32	25	17	200	45	23	4.5	-13°	-6°	0.8	TN□□1604□□	3.5
A32S-ATFNR/L16-D400	●	●	40	32	22	250	50	30	6	-10°	-6°	0.8	TN□□1604□□	3.5

AWLNR/L Boring and facing A-type (Negative rake, clamp-on system)

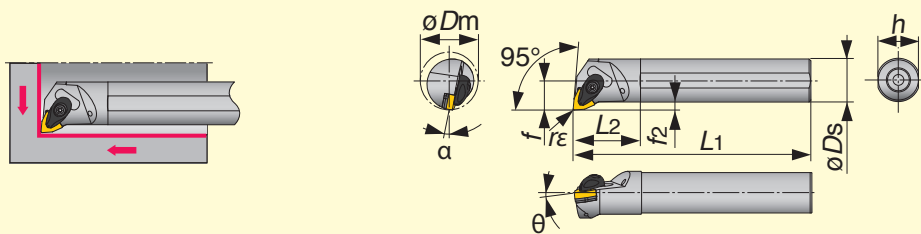

Cutting edge style: **L**

Right-hand (R) shown



Cat. No	Stock		Min. bore. dia.		Dimensions (mm)							Std. corner radius r_E	Insert	Torque (N·m)
	R	L	ϕD_m	ϕD_s	f	L_1	L_2	h	f_2	a	θ			
A25R-AWLNR/L0604-D320	★	★	32	25	17	200	45	23	4.5	-13°	-6°	0.8	WN□□0604□□E	3.0
A32S-AWLNR/L0604-D400	★	★	40	32	22	250	50	30	6	-10°	-6°	0.8	WN□□0604□□E	3.0
A25R-AWLNR/L08-D320	●	●	32	25	17	200	45	23	4.5	-13°	-6°	0.8	WN□□0804□□	3.5
A32S-AWLNR/L08-D400	●	●	40	32	22	250	50	30	6	-10°	-6°	0.8	WN□□0804□□	3.5
A40T-AWLNR/L08-D500	●	●	50	40	27	300	55	37	7	-8°	-6°	0.8	WN□□0804□□	3.5
A50U-AWLNR/L08-D630	●	●	63	50	35	350	65	47	10	-7°	-6°	0.8	WN□□0804□□	3.5

● : Stocked items
★ : Available in 2015

Parts for A-type toolholders

Toolholder Cat. No	Applicable inserts	Shim	Shim screw	Clamp	Clamping screw	Spring	Spring pin	Wrench
A□□□-ACLNR/L	CN□□0904□□E	ASC322	CSTB-3.5	ACP3S-E	ACS-5W	BP-7	SP-2.5	T-15F
A□□□-ACLNR/L	CN□□1204□□	ASC422	CSTB-3.5	ACP4S	ACS-5W	BP-7	SP-2.5	T-15F
A□□□-ADUNR/L	DN□□1104□□E	ASD322	CSTB-3.5	ACP3S-E	ACS-5W	BP-7	SP-2.5	T-15F
A□□□-ADUNR/L	DN□□1504□□	ASD432	CSTB-3.5	ACP4S	ACS-5W	BP-7	SP-2.5	T-15F
A□□□-ADUNR/L	DN□□1506□□	ASD423	CSTB-3.5	ACP4S	ACS-5W	BP-7	SP-2.5	T-15F
A□□□-ATFNR/L	TN□□1604□□	AST322	CSTB-3.5	ACP3S	ACS-5W	BP-7	SP-2.5	T-15F
A□□□-AWLNR/L	WN□□0604□□E	ASW322	CSTB-3.5	ACP3S-E	ACS-5W	BP-7	SP-2.5	T-15F
A□□□-AWLNR/L	WN□□0804□□	ASW422	CSTB-3.5	ACP4S	ACS-5W	BP-7	SP-2.5	T-15F

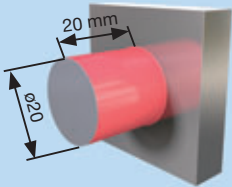
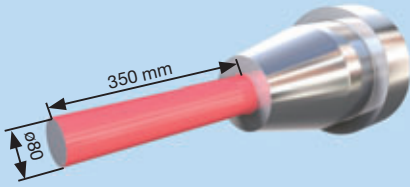
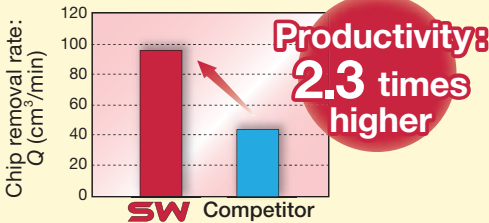
Practical examples

Workpiece type		Ball nut	Mold parts
Toolholder		ACLNR2525M12-A	ACLNR2525M12-A
Insert		CNMG120408-SW	CNMG120408-SW
Grade		T9125	T9115
Workpiece material		SCM418 / 18CrMo4	S40C / C40
		 P	 P
Cutting conditions	Cutting speed: V_c (m/min)	130	280
	Feed: f (mm/rev)	0.45	0.5
	Depth of cut: a_p (mm)	1.8	2.0
	Machining	External turning	External turning
	Coolant	Wet	Wet
Results		 <p>Chip removal rate: Q (cm³/min)</p> <p>Productivity 2.3 times higher</p> <p>SW Competitor</p> <p>SW chipbreaker allows high feed machining, which increases productivity by 2.3 times compared to the competitor.</p>	 <p>Stable cutting!</p> <p>SW Competitor</p> <p>SW chipbreaker provides stable machining without chattering, so the surface finish is better than the competitor.</p>

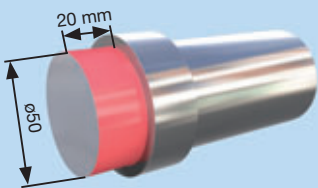
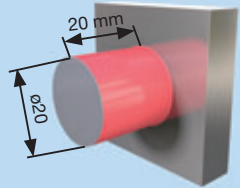
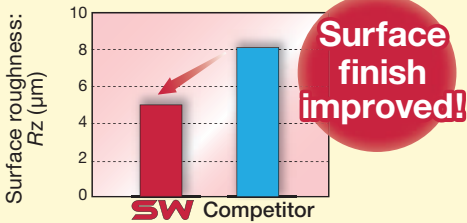
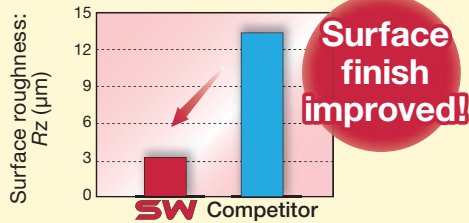
Workpiece type		Intermediate shaft	Nut
Toolholder		ACLNR2525M12-A	ACLNR2525M12-A
Insert		CNMG120408-SW	CNMG120408-SW
Grade		T9105	T9105
Workpiece material		SCM418 / 18CrMo4	SCM440 / 42CrMo4
		 P	 P
Cutting conditions	Cutting speed: V_c (m/min)	204	150
	Feed: f (mm/rev)	0.4	0.3
	Depth of cut: a_p (mm)	2.0	1.0 x 5 passes
	Machining	External turning	External turning
	Coolant	Wet	Wet
Results		 <p>Surface roughness: R_z (µm)</p> <p>Surface finish improved!</p> <p>SW Competitor</p> <p>SW chipbreaker improves surface finish by 40% even under the same cutting condition as the competitor's.</p>	 <p>Surface roughness: R_z (µm)</p> <p>Surface finish improved!</p> <p>SW Competitor</p> <p>SW chipbreaker provides better surface finish even under the same cutting condition as the competitor's. As a result, finishing operation can be skipped.</p>

Tungaloy Corporation (Head office)

11-1 Yoshima-Kogyodanchi
Iwaki-city, Fukushima, 970-1144 Japan
Phone: +81-246-36-8501
Fax: +81-246-36-8542
www.tungaloy.co.jp

Tungaloy America, Inc.

3726 N Ventura Drive
Arlington Heights, IL 60004, U.S.A.
Phone: +1-888-554-8394
Fax: +1-888-554-8392
www.tungaloyamerica.com

Tungaloy Canada

432 Elgin St. Unit 3
Brantford, Ontario N3S 7P7, Canada
Phone: +1-519-758-5779
Fax: +1-519-758-5791
www.tungaloy.co.jp/ca

Tungaloy de Mexico S.A.

C Los Arellano 113,
Parque Industrial Siglo XXI
Aguascalientes, AGS, Mexico 20290
Phone: +52-449-929-5410
Fax: +52-449-929-5411
www.tungaloy.co.jp/mx

Tungaloy do Brasil Comércio de Ferramentas de Corte Ltda.

Rua dos Sabias N.104
13280-000 Vinhedo, São Paulo, Brazil
Phone: +55-19-38262757
Fax: +55-19-38262757
www.tungaloy.co.jp/br

Tungaloy Germany GmbH

An der Alten Ziegelei 1
D-40789 Monheim, Germany
Phone: +49-2173-90420-0
Fax: +49-2173-90420-19
www.tungaloy.de

Tungaloy France S.A.S.

ZA Courtaboeuf - Le Rio
1 rue de la Terre de feu
F-91952 Courtaboeuf Cedex, France
Phone: +33-1-6486-4300
Fax: +33-1-6907-7817
www.tungaloy.fr

Tungaloy Italia S.r.l.

Via E. Andolfato 10
I-20126 Milano, Italy
Phone: +39-02-252012-1
Fax: +39-02-252012-65
www.tungaloy.it

Tungaloy Czech s.r.o.

Turanka 115
CZ-627 00 Brno, Czech Republic
Phone: +420-532 123 391
Fax: +420-532 123 392
www.tungaloy.cz

Tungaloy Ibérica S.L.

C/Miquel Servet, 43B, Nau 7
Pol. Ind. Bufalvent
ES-08243 Manresa (BCN), Spain
Phone: +34 93 113 1360
Fax: +34 93 876 2798
www.tungaloy.es

Tungaloy Scandinavia AB

S:t Lars Väg 42A
SE-22270 Lund, Sweden
Phone: +46-462119200
Fax: +46-462119207
www.tungaloy.se

Tungaloy Rus, LLC

36-D Harkovsky Lane
308009 Belgorod, Russia
Phone: +7 4722 24 00 07
Fax: +7 4722 24 00 08
www.tungaloy.co.jp/ru

Tungaloy Polska Sp. z o.o.

ul. Genewska 24
03-963 Warszawa, Poland
Phone: +48-22-617-0890
Fax: +48-22-617-0890
www.tungaloy.co.jp/pl

Tungaloy U.K. Ltd

The Technology Centre,
Wolverhampton Science Park
Glaisher Drive, Wolverhampton
West Midlands WV10 9RU, UK
Phone: +44 121 4000 231
Fax: +44 121 270 9694
www.tungaloy.co.jp/uk
salesinfo@tungaloyuk.co.uk

Tungaloy Hungary Kft

Erzsébet királyné útja 125
H-1142 Budapest, Hungary
Phone: +36 1 781-6846
Fax: +36 1 781-6866
www.tungaloy.co.jp/hu
info@tungaloytools.hu

Tungaloy Turkey

Dudullu, OSB 4. Cad No:4
34776 Umraniye Istanbul, TURKEY
Phone: +90 216 540 04 67
Fax: +90 216 540 04 87
www.tungaloy.com.tr
info@tungaloy.com.tr

Tungaloy Benelux b.v.

Tjalk 70
NL-2411 NZ Bodegraven, Netherlands
Phone: +31 172 630 420
Fax: +31 172 630 429
www.tungaloy-benelux.com

Tungaloy Croatia

Josipa Kozarca 4
10432 Bregana, Croatia
Phone: +385 1 3326 04 67
Fax: +385 1 3327 683
www.tungaloy.hr

Tungaloy Cutting Tool (Shanghai) Co., Ltd.

Rm No 401 No.88 Zhabei
Jiangchang No.3 Rd
Shanghai 200436, China
Phone: +86-21-3632-1880
Fax: +86-21-3621-1918
www.tungaloy.co.jp/tcts

Tungaloy Cutting Tool (Thailand) Co., Ltd.

TCIF Tower 4th Fl.
1858/5-7 Bangna-Trad Road
km.5 Bangna, Bangna, Bangkok 10260
Thailand
Phone: +66-2-751-5711
Fax: +66-2-751-5715
www.tungaloy.co.th

Tungaloy Singapore (Pte.), Ltd.

62 Ubi Road 1, #06-11 Oxley BizHub 2
Singapore 408734
Phone: +65-6391-1833
Fax: +65-6299-4557
www.tungaloy.co.jp/tspl

Tungaloy Vietnam

Unit 18, 4th Fl. Saigon Centre Building
65 Le Loi Blvd.
Dist 1, Ho Chi Minh City, Vietnam
Phone: +84-8-3827-0201
Fax: +84-8-3827-0203
www.tungaloy.co.jp/tspl

Tungaloy India Pvt. Ltd.

Unit#13, B wing, 8th Fl.
Kamala Mills Compound
Trade World, Lower Parel (West)
Mumbai - 4000 13, India
Phone: +91-22-6124-8804
Fax: +91-22-6124-8899
www.tungaloy.co.jp/in

Tungaloy Korea Co., Ltd

#1312, Byucksan Digital Valley 5-cha
Beotkot-ro 244, Geumcheon-gu
153-788 Seoul, Korea
Phone: +82-2-2621-6161
Fax: +82-2-6393-8952
www.tungaloy.co.jp/kr

Tungaloy Malaysia Sdn Bhd

50 K-2, Kelana Mall, Jalan SS6/14
Kelana Jaya, 47301
Petaling Jaya, Selangor Darul Ehsan
Malaysia
Phone: +603-7805-3222
Fax: +603-7804-8563
www.tungaloy.co.jp/my

Tungaloy Australia Pty Ltd

PO Box 2232, Rowville,
Victoria 3178, Australia
Phone: +61-3-9755-8147
Fax: +61-3-9755-6070
www.tungaloy.com.au

PT. Tungaloy Indonesia

Kompleks Grand Wisata Block AA-10 No.3-5
Cibitung
Bekasi 17510, Indonesia
Phone: +62-21-8261-5808
Fax: +62-21-8261-5809
www.tungaloy.co.jp/id



www.tungaloy.com

follow us at:

facebook.com/tungaloyjapan

twitter.com/tungaloyjapan

To see this product in action visit:

Tung-TV

www.youtube.com/tungaloycorporation

Distributed by:



DOWNLOAD
Dr. Carbide
Tungaloy



Available on the
App Store



GET IT ON
Google play



ISO 9001 Certified
QC00J0056
Tungaloy Corporation
18/10/1996

ISO 14001 Certified
EC97J1123
Tungaloy Group
Japan site and Asian
production site
26/11/1997

Produced from Recycled paper

Jun. 2015 (TJ)